



ENG Stereo Bluetooth Receiver

ESP Receptor de música Bluetooth stereo

RUS Стереo Bluetooth Receiver

DEU Récepteur Stéréo Bluetooth

FRA Stereo-Bluetooth-Empfänger

ITA Stereo Bluetooth Ricevitore

POR Estéreo Bluetooth Receptor

NL Stereo Bluetooth Receiver

REGULATIONS ACCORDING TO R&TTE DECLARATION OF CONFORMITY

Hereby, Armour Home Electronics declares that this uPlay® Stereo Bluetooth Receiver is in compliance with the

CE essential requirements and other relevant provisions of Directive 1999/5/EC, in conformity with the following standards:
EN300 328, EN301 489-1, EN301 489-17 and EN60950-1

The declaration of conformity is available at:

Armour Home Electronics
Stortford Hall Industrial Park,
Dunmow Road, Bishops Stortford,
Hertfordshire CM23 5GZ
United Kingdom

NOTE ON ENVIRONMENTAL PROTECTION

After the implementation of the European Directive 2002/96/EU the following applies:

Electrical and electronic devices may not be disposed of with domestic waste. Consumers are obliged by law to return electrical and electronic devices at the end of



their service lives to the public collecting points set up for this purpose or point of sale. For environmentally sound methods of disposal, please contact your local government agency. This symbol on the product, the instruction manual or the package

indicates that a product is subject to these regulations. By recycling, reusing the materials or other forms of utilizing old devices, you are making an important contribution to protecting our environment.

IMPORTANT SAFETY INSTRUCTIONS READ BEFORE OPERATING EQUIPMENT

This product was designed and manufactured to meet strict quality and safety standards.

There are, however, some installation and operation precautions which you should be particularly aware of.

1. Read these instructions.
2. Keep these instructions.
3. Heed all warnings.
4. Follow all instructions.
5. Do not use this apparatus near water.
6. Clean only with dry cloth.
7. Do not install near any heat sources such as radiators, heat registers, stoves, or other apparatus (including amplifiers) that produce heat.
8. Only use attachments/accessories specified by the manufacturer.

SPECIFICATION

Power supply: AC/DC Adapter
INPUT: 100–240V~50–60Hz 300mA
OUTPUT: DC 5V 500mA

Weight: 60g
Dimensions: Diameter=64.9mm
Height=18.7mm

Terminals: DC Input Port x 1
Audio Output x 1 (3.5mm Jack)
(Includes Phono adapter)

Comms method: Bluetooth V2.1+EDR
Range: Bluetooth Class 2 (Line of sight distance approx. 10m[†])

Frequency band: 2.400GHz to 2.4835GHz

Bluetooth profile: A2DP

Codecs: SBC, aptX®

[†]When used with a Power Class 2 Bluetooth Device. The transmission distance is approximate, performance may vary depending on the environment.

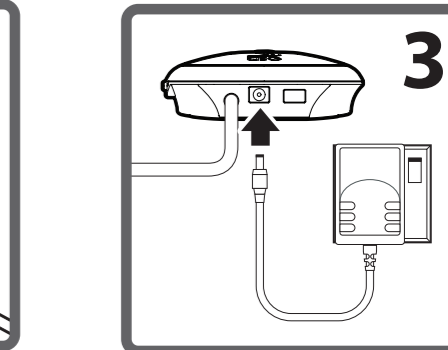
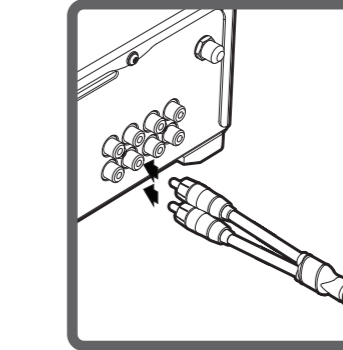
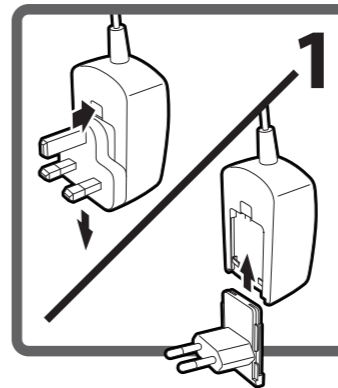



0.5s

4

- Press and hold
- Mantenga pulsada la tecla
- Нажмите и удерживайте
- Appuyez et maintenez
- Drücken und halten Sie
- Premere e tenere premuto
- Pressione e segure
- knopje indrukken en vast houden

PIN=0000

5

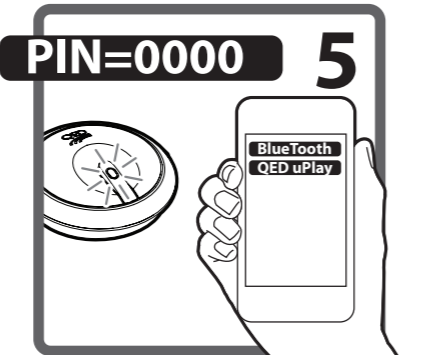

6



7

- Pairs with 4 devices
- Puede vincular con 4 dispositivos
- 4 пары с устройством
- Couples avec 4 dispositifs
- Paare mit 4 Geräte
- Coppie con 4 dispositivi
- Pares com 4 dispositivos
- Bruikbaar met 4 apparaten



5s

8

- Clear pairing list
- Clara la lista vinculación
- Открытый список сопряженных
- Effacer la liste d'appariement
- Klar Paarungsliste
- Cancella elenco associazione
- Lista de emparelhamento reset
- verwijder de lijst

uPlay and QED are registered trade marks ® of Armour Home Electronics Ltd. Our policy is one of continuous improvement and reserve the right to change the designs and specifications without notice.

uPlay y QED son marcas comerciales registradas ® de Armour Home Electronics Ltd. Nuestra política se basa en la mejora continua. Nos reservamos el derecho a modificar los diseños y especificaciones sin previo aviso.

uPlay и QED – зарегистрированные торговые марки ® Armour Home Electronics Ltd. Наша политика предусматривает непрерывное улучшение, и мы оставляем за собой право на изменение конструкции и спецификаций без уведомления.

uPlay et QED sont des marques déposées ® d'Armour Home Electronics Ltd. En raison de notre politique d'amélioration continue, nous nous réservons le droit de modifier la conception et les spécifications sans préavis.

uPlay und QED sind eingetragene Marken ® von Armour Home Electronics Ltd. Wir bemühen uns ständig um Innovationen und behalten uns das Recht vor, die Konstruktionen und Spezifikationen ohne vorherige Ankündigung zu ändern.

uPlay e QED sono marchi registrati ® di Armour Home Electronics Ltd. La nostra filosofia consiste nel continuo miglioramento dei nostri prodotti e pertanto ci riserviamo il diritto di apportare modifiche alla forma e alle funzioni del prodotto senza preavviso.

uPlay e QED são marcas comerciais registadas ® da Armour Home Electronics Ltd. A nossa política é a de melhorar continuamente os nossos produtos e reservamos o direito de alterar o design e as especificações sem aviso.

UPplay en QED zijn geregistreerde merken van Armour Home ElectronicsLtd. Ons beleid is van continue verbetering en wij behouden de rechten om de specificaties en de ontwerpen van het produkt aan te passen zonder aankondiging